

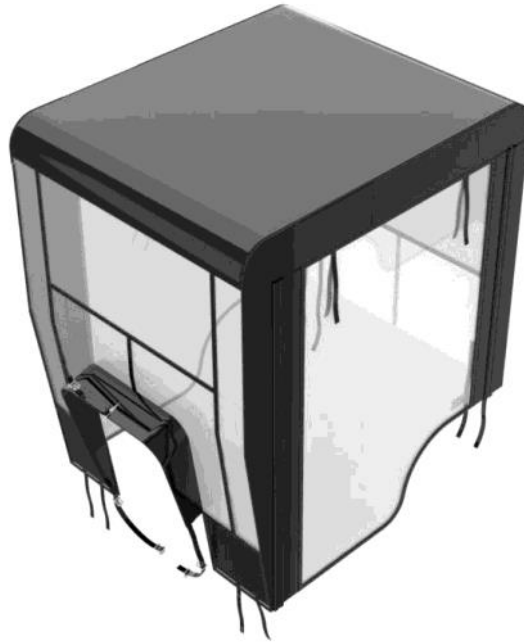

OWNER'S MANUAL
Model Number

700423-2 Tractor Winter Cab



BERCO
Universal Mounting Tractor Cab

- * ASSEMBLY
- * OPERATION

- * REPAIR PARTS
- * MAINTENANCE

CAUTION:
READ & FOLLOW ALL SAFETY RULES & INSTRUCTIONS BEFORE
OPERATING YOUR EQUIPMENT



LIMITED WARRANTY

Conditions and Products Covered:

BERCOMAC guarantees any part of the product or accessory manufactured by BERCOMAC and found in the reasonable judgment of BERCOMAC to be defective in material and or workmanship will be repaired or replaced by an authorized dealer without charge up to our maximum labor rates and pre-established times. For replacement parts only standard ground freight services are covered. This warranty extends to the original retail purchaser only and is not transferable to any subsequent purchasers. This warranty applies to the products bought and used in North America.

Warranty Period

(from date of the original retail purchase)

- Residential use: 1 year
- Semi-commercial, professional or rental use: 90 days

Exceptions Noted Below; the following items are guaranteed by the original manufacturer and have their own warranty, conditions and limited time:

- Tire Chains: 90 days
- Engines: Will vary as per the manufacturer
Please refer to the engine manufacturer's warranty statement included with the unit. BERCOMAC is not authorized to handle warranty adjustments on engines.

Items and Conditions NOT Covered:

This warranty does not cover the following:

- Pick-up or delivery charges or in-home services fees.
- Any damage or deterioration of the unit, parts and or finish of these due to normal use, wear and tear, or exposure.
- Cost of regular use or maintenance service or parts, such as gas, oil, lubricants, tune-up parts, and adjustments.
- Any part or accessory which has been altered, modified, misused, neglected, accidentally damaged or not properly installed, maintained, stored or repaired not in accordance with the instructions in the owner's manual.
- Repair due to normal wear and or any wear items such as shear pins, bolts, belts, etc.
- Expedited freight fee services for replacement parts.
- Shear bolts and shear pins are to be considered as a preventive measure not as an assured protection, any damages resulting from the lack of shear bolts breakage are not covered.
- Damages due to product being installed on a vehicle other than stipulated in owner's manual.

NOTE: All warranty work must be performed by an authorized dealer using original (manufacturer) replacement parts.

NOTE: Bercomac reserves the right to change or improve the design of any part or accessory without assuming any obligation to modify any product previously manufactured.

Instructions for Obtaining Warranty Services:

Contact dealer where equipment was purchased or any other BERCO service dealer to arrange service at their dealership. Requests for warranty claims must be carried out through the same distribution network used to purchase the product. Don't forget to bring your proof of purchase (sales receipt) to the BERCOMAC dealer.

Owner's Responsibilities:

BERCOMAC's defective equipment or part must be returned to an authorized dealer within the warranty period for repairs. In the event that defective merchandise must be returned to manufacturer for repairs, freight fees are prepaid and a written authorization from BERCOMAC must be obtained by dealer prior to the shipment. This warranty extends only to equipment operated under normal conditions. To validate a warranty claim, it is the user's responsibility to maintain and service the unit as specified in the owner's manual or to have the unit serviced at their dealer at their expense.

General Conditions:

The sole liability of BERCOMAC with respect to this warranty shall be strictly and exclusively repair and replacement as mentioned herein. BERCOMAC shall not have any liability for any other costs, loss or damage, including but not limited to, any incidental or consequential loss or damage. Taking advantage of the warranty does not in any way extend the length or renewal of the warranty.

In particular, without being limited to, BERCOMAC shall have no liability or responsibility for:

- Travel time, overtime, after hours time or other extraordinary repair charges or relating to repairs and or replacements outside of normal business hours.
- Rental of like or similar replacement equipment during the period of any, repair or replacement work.
- Any communicating or travel charges.
- Loss or damage to person or property other than that covered by the terms of this warranty.
- Any claims for lost revenue, lost profit or any similar costs as a result of damage or repair.
- Attorney's fees.

BERCOMAC's responsibility in respect to claims is limited to making the required repairs or replacement without charge up to our maximum labor rates and pre-established times and no claim of breach of warranty shall be cause for cancellation or rescission of the contract of sale of any product or accessory. In no event recovery of any kind be greater than the amount of the purchase price of the product sold.

This warranty gives you specific legal rights. You may also have other rights, which vary from state to state.

TABLE OF CONTENTS

PAGE

INTRODUCTION	2
SAFETY PRECAUTIONS	3
SAFETY DECALS	5
ASSEMBLY	
Installation Information	6
Tools Required	6
Step 1: Frame Assembly—Roof	6
Step 2: Tow Hitch Support Installation	7
Step 3: Front Attaching Plates Installation	8
Step 4: Front Rod Support Installation	8
Step 5: Frame Assembly.....	9
Step 6: Canvas Installation	9
OPERATION	11
MAINTENANCE	12
PARTS BREAKDOWN AND LISTS	
Cab	13
TORQUE SPECIFICATION TABLE	15

INTRODUCTION

TO THE PURCHASER

This new accessory was carefully designed to give years of dependable service. This manual has been provided to assist in the safe operation and servicing of your attachment.

NOTE: All photographs and illustrations in the manual may not necessarily depict the actual models or attachment, but are intended for reference only and are based on the latest product information available at the time of publication.

Familiarize yourself fully with the safety recommendations and operating procedures before putting the machine to use. Carefully read, understand and follow these recommendations and insist that they be followed by those who will use this attachment.



THIS SAFETY ALERT SYMBOL IDENTIFIES AN IMPORTANT SAFETY MESSAGE IN THIS MANUAL THAT HELPS YOU AND OTHERS AVOID PERSONAL INJURY OR EVEN DEATH. DANGER, WARNING, AND CAUTION ARE SIGNAL WORDS USED TO IDENTIFY THE LEVEL OF HAZARD. HOWEVER, REGARDLESS OF THE HAZARD, BE EXTREMELY CAREFUL.

DANGER: Signals an extreme hazard that will cause serious injury or death if recommended precautions are not followed.

WARNING: Signals a hazard that may cause serious injury or death if the recommended precautions are not followed.

CAUTION: Signals a hazard that may cause minor or moderate injury if the recommended precautions are not followed.

Record your attachment serial number and purchase date in the section reserved below (there is no serial number on the subframe). Your dealer requires this information to give you prompt, efficient service when ordering replacement parts. Use only genuine parts when replacements are required.

If warranty repairs are required please present this registration booklet and original sales invoice to your selling dealer for warranty service.

This manual should be kept for future reference.

Please check if you have received all the parts for your kit with the list of the bag and the list of the box.

SERIAL NUMBER : _____
(IF APPLICABLE)

MODEL NUMBER: _____

PURCHASE DATE : _____



SAFETY PRECAUTIONS



Careful operation is your best insurance against an accident. Read this section carefully before operating the vehicle and accessory. This accessory is capable of amputating hands and feet and throwing objects. Failure to observe the following safety instructions could result in serious injury. All operators, no matter how experienced they may be, should read this and other manuals related to the vehicle and accessory before operating. It is the owner's legal obligation to instruct all operators in safe operation of the accessory.

GLOSSARY:

In this manual, right and left sides are determined by sitting on the seat of the vehicle facing forward.

In this manual, "accessories" means attachments (snowblower, rotary broom, blade etc.) that you install on the vehicle (lawn tractors, A.T.V. s etc).

TRAINING:



This symbol, "Safety Alert Symbol", is used throughout this manual and on the accessory's safety labels to warn of the possibility of serious injury. Please take special care in reading and understanding the safety precautions before operating the vehicle and accessory.

1. Read this owner's manual carefully. Be thoroughly familiar with the controls and proper use of the vehicle and accessory. Know how to stop the unit and disengage the controls quickly.
2. Never allow children to operate the vehicle nor the accessory. Never allow adults to operate the vehicle nor the accessory without proper instructions.
3. No one should operate the vehicle nor the accessory while intoxicated or while taking medication that impairs the senses or reactions.
4. Keep the area of operation clear of all people, particularly small children and pets.
5. Never start or operate the accessories except from the operator's station on the power unit except if this is impossible.

PREPARATION:

1. Thoroughly inspect the area where the accessory is to be used and remove door mats, all foreign objects and the like.
2. For motorized accessories, disengage all clutches and shift into neutral before starting engine.
3. Do not operate the accessory without wearing adequate winter outer garments. Avoid loose fitting clothing that can get caught in moving parts. Wear footwear that will improve footing on slippery surfaces.

4. Handle fuel with care, it is highly flammable.
 - a) Use approved fuel container.
 - b) Never add fuel to a running engine or hot engine.
 - c) Fill fuel tank outdoors with extreme care. Never fill fuel tank indoors.
 - d) Never fill containers inside a vehicle, or on a truck or a trailer bed with a plastic liner. Always place containers on the ground, away from your vehicle, before filling.
 - e) When practical, remove gas-powered equipment from the truck or trailer and refuel it on the ground. If this is not possible, then refuel such equipment on a trailer with a portable container, rather than from a gasoline dispenser nozzle.
 - f) Keep the nozzle in contact with the rim of the fuel tank or container opening at all times, until refueling is complete. Do not use a nozzle lock-open device.
 - g) Replace fuel cap securely and wipe up spilled fuel.
 - h) If fuel is spilled on clothing, change clothing immediately.
5. Never attempt to make any adjustments while the engine (motor) is running (except when specifically recommended by manufacturer).
6. Let the vehicle and accessory adjust to outdoor temperatures before using.
7. Never use an accessory without proper guards, plates, or other safety protective devices in place
8. Always make sure to wear the appropriate safety equipment required (glasses, muffs, mask...) for each type of product. See operation section.
9. Always make sure of having safe traction on the vehicle by using the recommended accessories (chains, A.T.V. tracks, counterweights...). See operation section.
10. Always make sure all components are correctly installed. (driveline securely attached and locked at both ends, belts properly installed...)
11. If applicable, always handle the winch cable with thick leather gloves.
12. **Never modify the accessory or any part without the written consent from the manufacturer.**



SAFETY PRECAUTIONS



OPERATION:

1. Do not put hands or feet near, under or inside rotating parts.
2. Exercise extreme caution when operating on or crossing gravel drives, walks or roads. Stay alert for hidden hazards or traffic. Do not carry passengers.
3. After striking a foreign object, stop the engine (motor), disconnect the wire from the spark plug(s) and keep wire away to prevent accidental starting. Thoroughly inspect the accessory for any damage and repair damage before restarting and using the accessory.
4. If the unit should start to vibrate abnormally, stop the engine (motor) and check immediately for the cause. Vibration is generally a warning of trouble.
5. Take all possible precautions when leaving the vehicle unattended. Disengage the power take-off, lower the attachment, place the transmission into neutral, set the parking brake, stop the engine and remove the ignition key.
6. Do not run the engine indoors, except when starting the engine and for transporting in or out of the building. Do not operate or let motor run in a storage area without ventilation because gas contains carbon monoxide which is odorless, colorless and can cause death.
7. Never use the accessories across the face of slopes, go from top to bottom. Exercise extreme caution when using equipment on slopes. Do not attempt to clear a steep slope.
8. Never tolerate bystanders in the working zone. Never use an accessory in the direction of bystanders, it might throw gravel or debris that can hurt people or damage property.
9. Never operate the accessory at high transport speeds on slippery surfaces. Use care when backing up.
10. Do not carry passengers.
11. Disengage power to the accessory when it is transported or not in use.
12. Never operate the accessory without good visibility or light.
13. Keep the accessory away from heat sources or flames.
14. If applicable, never handle the winch cable or hook while in tension.

MAINTENANCE AND STORAGE

1. When cleaning, repairing or inspecting the vehicle and accessory: stop the engine, set brake, remove ignition key, and wait that all moving parts have stopped. For gasoline engine, disconnect wire from the spark plug(s) and keep wire away to prevent accidental starting.
2. Check all the bolts and components at frequent intervals to make sure that they are properly tightened.
3. Never store a motorized accessory with fuel in the fuel tank inside a building where ignition sources are present such as hot water and space heaters, clothes dryers, and the like. Allow the engine to cool before storing in any enclosure.
4. Always refer to the owner's manual when you store the accessory and vehicle for a prolonged or an unspecified length of time.
5. Maintain or replace safety and instruction labels, as necessary.
6. For winter accessories, (if applicable), let the engine run for a few minutes after clearing snow in order to prevent the rotary parts from freezing.
7. Inspect the vehicle's and accessory's air filter (if applicable) every day. Clean it or replace it as necessary. Change the oil more often when working in dusty conditions. See the vehicle's and accessory's owner's manual.

TRANSPORT

1. Review Transport Safety instructions in vehicle manual before moving.
2. Check with local authorities regarding transport on public roads. Obey all applicable laws and regulations.
3. Make sure all lights and reflectors that are required by the local highway and transport authorities (example : SMV (Slow Moving Vehicle)) are in place, are clean, and can be seen clearly by all overtaking and oncoming traffic.
4. Never have the equipment in operation during transport.
5. Always travel at a safe speed.



SAFETY DECALS



REPLACE IF DECALS ARE DAMAGED
SEE PARTS BREAKDOWN FOR DECAL LOCATION

Symbol	Description
<p data-bbox="256 443 456 474">Decal #107160</p> 	<p data-bbox="597 480 1321 512">Carbon monoxide (CO) can cause brain damage or death.</p> <p data-bbox="597 539 1430 596">Engine exhaust contains odorless and colorless carbon monoxide gas.</p> <p data-bbox="597 625 1406 682">Signs of carbon monoxide poisoning include nausea, headache, dizziness, drowsiness, and lack of consciousness.</p> <p data-bbox="597 711 1446 743">Get fresh air if anyone shows signs of carbon monoxide poisoning.</p> <p data-bbox="597 770 1373 827">Read all Owner's Manual safety precautions regarding carbon monoxide poisoning.</p>

ASSEMBLY

INSTALLATION INFORMATION:

If this cab is being installed on a tractor which already is equipped with a Berco attachment, the subframe (certain but not necessarily all models of subframes) have existing attaching points welded to the mounting supports.

IMPORTANT: There is a potential risk of the paint wearing off from the hood or the decal coming off due to cab rubbing against it. To lessen this potential damage, a soft cloth may be inserted between the cab and hood. Wiping down the hood after each use will also help.

NOTE: (for the winter cab) The windows are made of top quality cold resistant, clear flexible plastic. Under extreme cold conditions, all plastics become fragile. Never hit or scrape windows, this could damage them. These damages, under these conditions, are not covered by the manufacturer's warranty.

STEP 1 FRAME ASSEMBLY—ROOF:

Assemble the top portion of the frame by attaching the link tubes (fig.1, item 1) to the side tubes (item 2) and in the middle, the reinforcement tube (item 3) (angled portion facing upwards).

Secure loosely with the #10 x 1" machine screws (item 4) (screw heads on top) with the nylon insert lock nuts (item 5).

Place the assembly on a level surface to ensure that the structure is level.

Tighten all the screws firmly.

TOOLS REQUIRED:

- 1-Drill
- 1-9/32" (0.281") bit
- 1-Philips screwdriver
- 1-3/8" wrench
- 1-7/16" wrench
- 1-3/4" wrench
- 1-3/4" adjustable wrench
- 1-5/32" Allen key

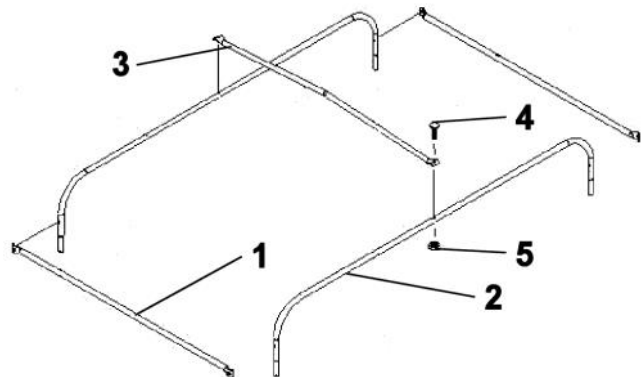

Figure 1

INSTALLATION OF ROOF REINFORCEMENT:

Position roof reinforcement (fig.2, item 1) onto frame's assembly (fig.2, item 2) and connect together with 18 nylon tie wraps.

Note: Be sure that the nylon tie wraps pass around the side tubes.

Note: Only tighten nylon tie wraps once the roof's reinforcement is centered onto the frame's assembly insuring the head's of the tie wraps are underneath the roof.

Cut off any exceeding tie wraps.

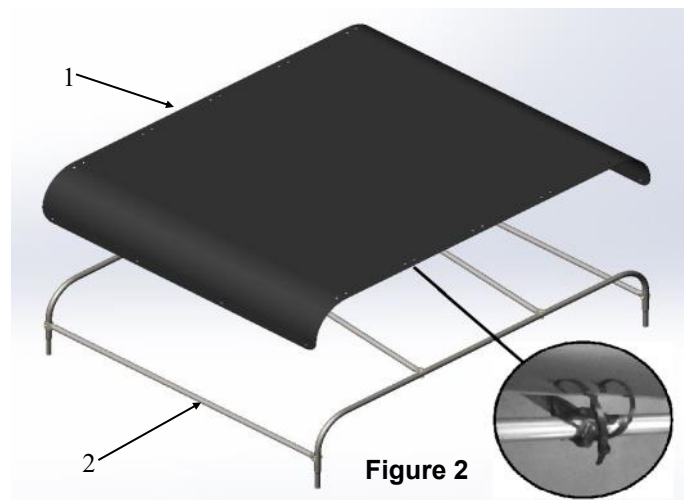

Figure 2

ASSEMBLY

STEP 2 TOW HITCH SUPPORT INSTALLATION:

NOTE: If you have a Berco counterweight kit installed on the back on the tractor, it is not necessary to install the tow hitch support (item 2) (except if the 700240 is installed). The rear support rods (item 1) of the cab will be inserted into the tubes welded to the right and left support plates of the counterweight kit.

Insert the rear support rods (fig.2, item 1), the longest end into tow hitch support or the counterweight support (item 2).

Install the tow hitch support on top of the tractor tow hitch (item 3) with a 1/2 x 1 1/2" hex bolt and two flat washers (item 5) (one on top and the other under the tow hitch), lockwasher and nut.

The support must be completely flat against the back of the tow hitch.
Tighten firmly.

Adjust the horizontal section of the rear rod support (fig.2, item A), so it is located 1/8" below the mud guard and 1" behind the mud guard.
Secure in place with two 5/16 x 5/16 set screws (item 4).

Tighten lightly.

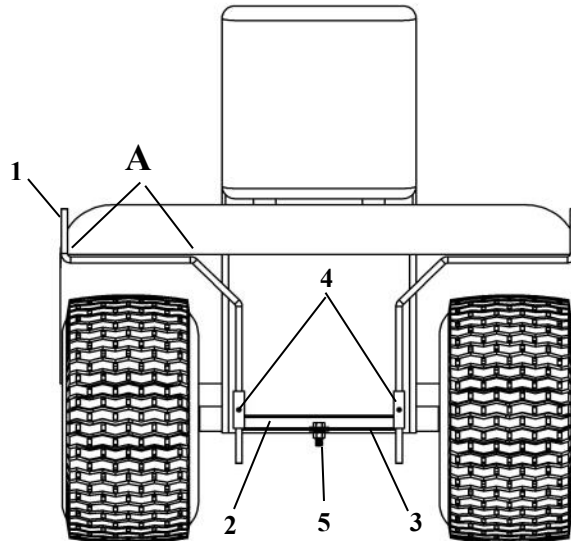

Figure 2

ASSEMBLY

STEP 3 FRONT ATTACHING PLATES INSTALLATION:

If this cab is being installed on a tractor which already is equipped with a Berco attachment, the subframe (some but not necessarily all models of subframes) may have existing attaching points welded to the mounting supports. **If so, go to Step 4**

The supports furnished with this kit consist of three separate parts and can be installed in four different ways to adapt to the footrests.

BEFORE DRILLING HOLES IN FOOTRESTS

Determine the best location to mount the support plates by respecting the following:

- Plates must **NOT** interfere with any tractor pedals or controls such as brakes, clutch.

Tractors with snowblowers:

- Snowblower controls (lift arm and chute rotation support) must remain inside cab.

TIP: Temporarily install the whole cab on the tractor to get a global view of the installation before drilling the holes to attach the front supports. You can hold the supports temporarily in place with either C locking pliers or C clamps until deciding where to secure it.

When the location has been determined, drill two 9/32" holes in each footrest. If needed, unclip and lift the rubber pads from the footrests. Install the front attaching plates (fig.3, item 4) under the footrests using two 1/4 x 3/4" machine screws (item 1) and flange nuts (item 5). Tighten firmly.

Fasten the front supports (item 6) to the attaching plates (item 4) with two 1/4 x 3/4" hex bolts (item 3) and flange nuts (item 5). Tighten firmly.

NOTE: On certain tractor models, the attaching plate (item 4) is not required. Simply bolt the front support (item 6) directly to the front lip of the footrest, after drilling the 9/32" holes.

STEP 4 FRONT ROD SUPPORT INSTALLATION

Slide the front rod supports (item 7) into the front supports or into the tubes welded to the subframe. You may have to cut the rod.

Adjust the width of the rods to 39" from one side of the tractor to the other. Secure in place with the 5/16 x 5/16" allen set screws (item 8). Secure moderately.



WARNING



TO AVOID PERSONAL INJURY:

The front supports must not interfere in anyway with the brake & clutch pedals or any other tractor controls at any time. Any interference from the supports may block the controls and cause an accident.

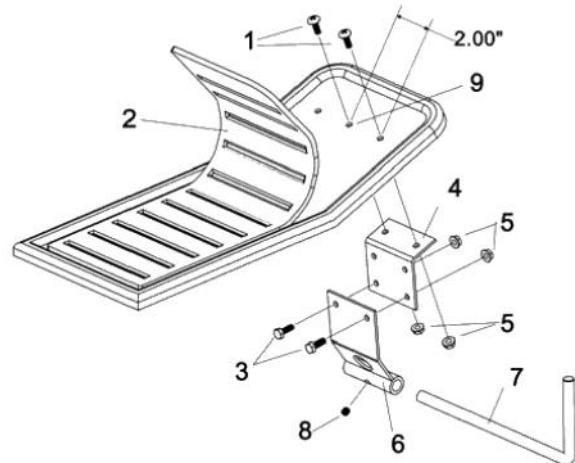

Figure 3

ASSEMBLY

STEP 5 FRAME ASSEMBLY:

Install the front posts (fig.4, item 2) the bent part towards the front and the back posts (item 1) as shown.

Place the roof section onto the posts .

NOTE:

If the cab is not level, adjust the front supports (if used) by screwing them in the other set of holes on the plates.

If the front posts need to be lengthened, place two sleeves on the support rods.

If front posts need to be shortened, cut bottom portion of posts as needed.

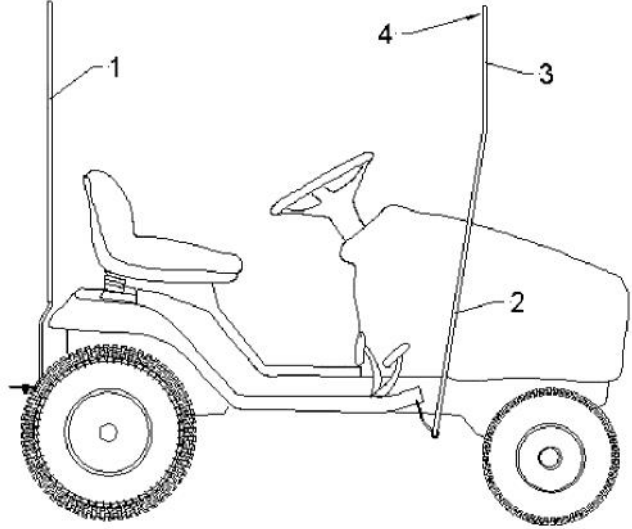

Figure 4

STEP 6 CANVAS INSTALLATION:

Install the cab cover over the frame. Use the Velcro straps to tie it down to the frame. The front of the cab is designed with an opening which allows access under the hood.

Attach the straps to the supports (fig.3, item 6) by inserting the buckles (fig.5, items 2 & 3) through the holes on the supports then snapping one end into the other. If the front supports are not used, wrap the straps around the tubes welded on the subframe and snap the buckles.

Adjust the buckle (item 4) on top of the hood so that it is centered after adjusting all the other straps.

Once installation is complete, adjust the cab by pulling the rear support rods (fig.2, item 1) toward the back to achieve a snug fit.

Tighten all the nuts and screws firmly.

OPENING FOR HANDLE:

To accommodate the handle for the accessories, open the "Velcro" seam (item 1) on either side.

BEFORE INITIAL USE, PLEASE WIPE THE WHITE RESIDUE OFF THE WINDOWS WITH A DRY SOFT CLOTH.

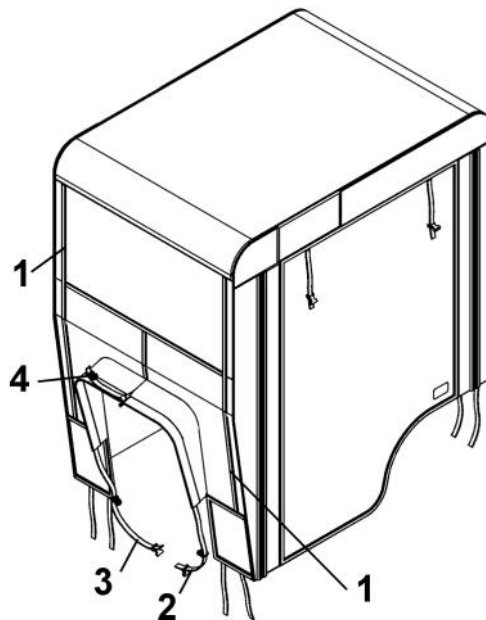

Figure 5

ASSEMBLY



WARNING



TO AVOID PERSONAL INJURY:

Make sure the cab cover does not touch the tractor's muffler or exhaust system. The cab may be damaged or even catch on fire.



WARNING



- Never block the air vents.
- As this is an universal cab, there is many tractor models, makes and options that can affect the quantity of carbon monoxide (CO) in the cab.
- Carbon monoxide (CO) can cause brain damage or death.
- Exhaust fumes should never enter the cab, they contain carbon monoxide (CO) which is odorless, colorless and deadly.
- It is the installer's/owner's/user's responsibility to make sure no carbon monoxide (CO) is entering the cab at any time. To do that; make sure the tractor's exhaust system is in good condition and not oriented towards the cab.
- The installer/owner/user must buy and install a carbon monoxide (CO) detector to be placed inside the cab that suit the use of the cab.
 - For a commercial application (8hour/day max) the detection level must be lower than 35ppm
 - For a residential application (1hour/day max) the detection level must be lower than 200ppm
 - The detector must be working at a temperature range that suits the temperature range where the cab is being used. The same goes for the humidity level.
 - Use and install the CO detector following it's manufacturer's instructions.
 - The CO detector must be keep functional and in good condition at all time.
- If any question contact Bercomac's support.



WARNING



- Diesel exhaust fumes contains gases and particles
- Diesel exhaust is classified : "carcinogenic to humans" by WorldHealthOrganization
- It is the installer's/owner's/user's responsibility to make sure that exhaust fumes should never enter the cab

OPERATION

OPERATION

- a) Keep the windows clear and clean in order to keep a good visibility at all times. Wash the windows with a mild soap such as dishwashing soap and a soft cloth.
- b) During the winter use a soft brush to sweep off the snow. DO NOT HIT the windows with the brush or your hands to remove the snow. This will crack the vinyl.
- c) Keep air vents clear and clean at all times.



WARNING



- Never block the air vents.
- As this is an universal cab, there is many tractor models, makes and options that can affect the quantity of carbon monoxide (CO) in the cab.
- Carbon monoxide (CO) can cause brain damage or death.
- Exhaust fumes should never enter the cab, they contain carbon monoxide (CO) which is odorless, colorless and deadly.
- It is the installer's/owner's/user's responsibility to make sure no carbon monoxide (CO) is entering the cab at any time. To do that; make sure the tractor's exhaust system is in good condition and not oriented towards the cab.
- The installer/owner/user must buy and install a carbon monoxide (CO) detector to be placed inside the cab that suit the use of the cab.
 - For a commercial application (8hour/day max) the detection level must be lower than 35ppm
 - For a residential application (1hour/day max) the detection level must be lower than 200ppm
 - The detector must be working at a temperature range that suits the temperature range where the cab is being used. The same goes for the humidity level.
 - Use and install the CO detector following it's manufacturer's instructions.
 - The CO detector must be keep functional and in good condition at all time.
- If any question contact Bercomac's support.



WARNING



- Diesel exhaust fumes contains gases and particles
- Diesel exhaust is classified : "carcinogenic to humans" by WorldHealthOrganization
- It is the installer's/owner's/user's responsibility to make sure that : exhaust fumes should never enter the cab



WARNING



WEARING EAR MUFFS IS REQUIRED WHILE OPERATING THE TRACTOR WITH THE CAB



WARNING



TO AVOID PERSONAL INJURY CAUSED BY CAB COLLAPSING: Remove any accumulation on the top of the cab



WARNING



KEEP ALL FLAME AND HEAT SOURCES AWAY FROM THIS TRACTOR WINTER CAB

MAINTENANCE

MAINTENANCE

Check mounting bolts on the frame at frequent intervals for proper tightness to be sure equipment is in safe working condition.

END OF SEASON STORAGE

- a) Thoroughly wash and dry the canvas.
- b) Inspect for any tears or unstitched seams. Repair if necessary.
- c) Carefully remove the canvas from the frame.
- d) Roll up instead of folding the canvas for summer storage.
- e) Store the canvas in a well ventilated place, away from all weather elements and out of reach of rodents.
- f) The frame must be cleaned and dried before storing in a dry enclosed place.
- g) Inspect and replace all defective parts before using again.

PARTS BREAKDOWN CAB

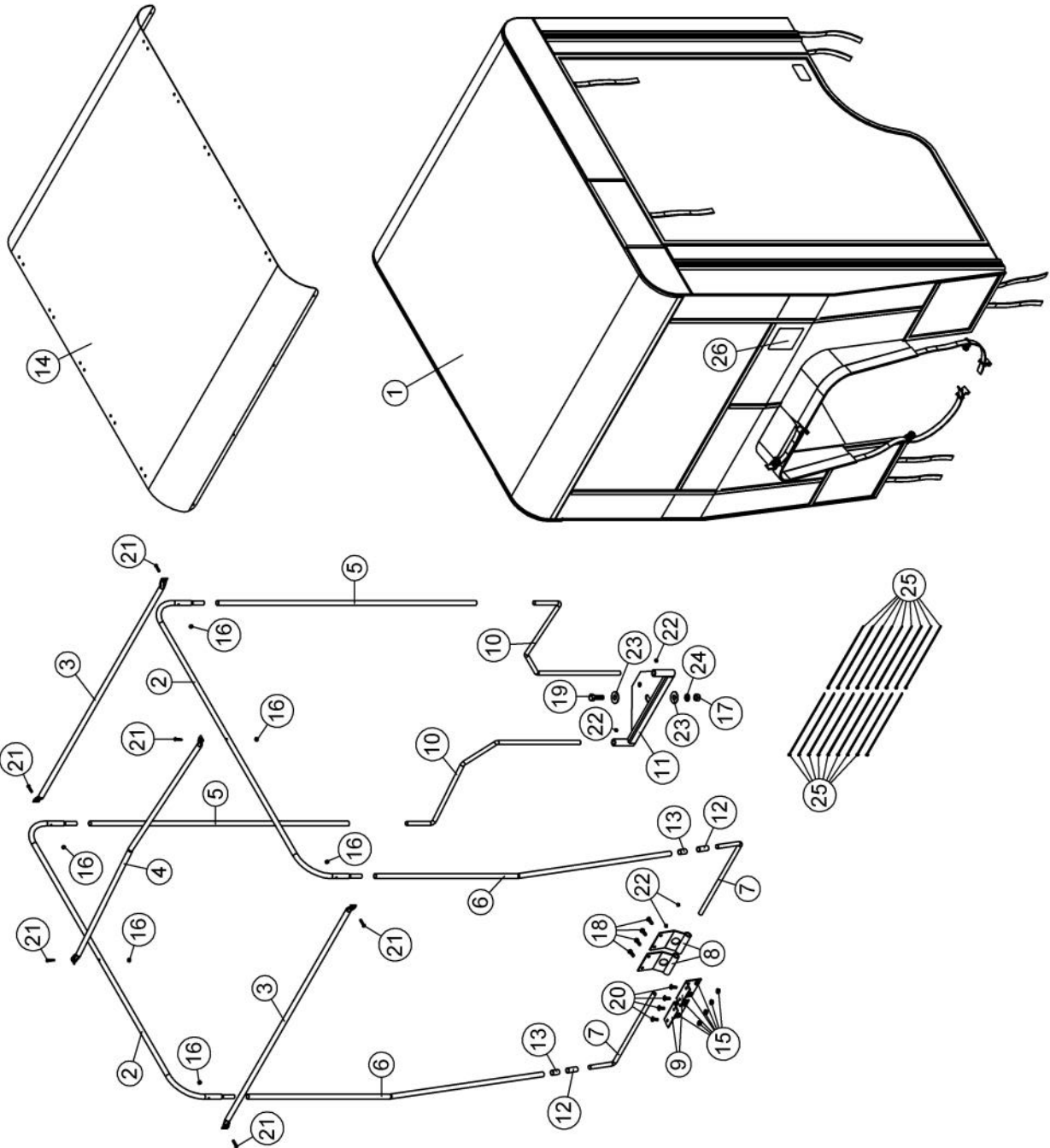

NOMENCLATURE ET LISTE DES PIÈCES / PARTS BREAKDOWN & PART LIST
Cabine d'hiver pour tracteur #700423-2
Tractor winter cab #700423-2

REF.	ENGLISH DESCRIPTION	DESCRIPTION FRANÇAISE	QTY.	PART#
1	Berco winter canvas	Toile d'hiver Berco	1	105438
2	Side tube	Tube de côté	2	102945
3	Link tube	Tube de liaison	2	104353
4	Reinforcement tube	Tube de renforcement	1	104354
5	Rear post	Poteau arrière	2	102948
6	Front post	Poteau avant	2	102949
7	Front rod support	Tige de support avant	2	104355
8	Front support	Support avant	2	102951
9	Front attaching plate	Plaque d'attache avant	2	102952
10	Rear rod support	Tige de support arrière	2	104356
11	Tow hitch support	Support de la barre de remorquage	1	104393
12	Sleeve	Douille	2	103215
13	Sleeve	Douille	2	104145
14	Roof stiffener	Renfort de toit	1	107717
15	Flange nut 1/4" n.c.	Écrou à bride 1/4" n.c.	8	O/L (FN_1-4)
16	Nylon insert lock nut #10 x 24	Écrou à garniture de nylon #10 x 24	6	O/L (NLN_#10)
17	Hex. nut 1/2" n.c.	Écrou hex. 1/2" n.c.	1	O/L (HN_1-2)
18	Hex. bolt 1/4" n.c. x 3/4" GR5	Boulon hex. 1/4" n.c. x 3/4" GR5	4	O/L (300NC.5P_1-4x3-4)
19	Hex. bolt 1/2" n.c. x 1 1/2"	Boulon hex. 1/2" n.c. x 1 1/2"	1	O/L (HB_1-2_1-1-2)
20	Machine screw T.H. 1/4" n.c. x 3/4"	Vis mécanique T.H. 1/4" n.c. x 3/4"	4	O/L (Trust_1-4_3-4)
21	Machine screw P.H. #10 x 24 x 1"	Vis mécanique P.H. #10 x 24 x 1"	6	O/L (MachP_#10_1)
22	Hex. socket set screw 5/16" n.c. x 5/16"	Vis à pression hex. 5/16" n.c. x 5/16"	4	O/L (HAL_5-16_5-16)
23	Flat washer 9/16" hole	Rondelle plate 9/16" trou	2	O/L (FLAT_9-16)
24	Lock washer 1/2"	Rondelle de blocage 1/2"	1	O/L (lock_1-2)
25	Tie wrap 11"	Attache de nylon 11"	18	O/L (426-11)
26	Decal warning CO	Décalque avertissement CO	1	107160

O/L = Obtain Locally

TORQUE SPECIFICATION TABLE

GENERAL TORQUE SPECIFICATION TABLE USE THE FOLLOWING TORQUES WHEN SPECIAL TORQUES ARE NOT GIVEN

NOTE: These values apply to fasteners as received from supplier, dry or when lubricated with normal oil. They do not apply if special graphited or moly disulphide greases or other extreme pressure lubricants are used. This applies to both UNF and UNC threads.

* Thick nuts must be used with grade 8 bolts

SEE Grade No.		2				5				8 *			
BOLT HEAD IDENTIFICATION MARKS AS PER GRADE NOTE MANUFACTURING MARKS WILL VARY		TORQUE				TORQUE				TORQUE			
BOLT SIZE		FOOT POUNDS		NEW TON-METERS		FOOT POUNDS		NEW TON-METERS		FOOT POUNDS		NEW TON-METERS	
Inches	Millimetre	Min.	Max.	Min.	Max.	Min.	Max.	Min.	Max.	Min.	Max.	Min.	Max.
1/4"	6.35	5	6	6.8	8.13	9	11	12.2	14.9	12	15	16.3	30.3
5/16"	7.94	10	12	13.6	16.3	17	20.5	23.1	27.8	24	29	32.5	39.3
3/8"	9.53	20	23	27.1	31.2	35	42	47.5	57	45	54	61	73.2
7/16"	11.11	30	35	40.7	47.4	54	64	73.2	86.8	70	84	94.9	113.9
1/2"	12.7	45	52	61	70.5	80	96	108.5	130.2	110	132	149.2	179
9/16"	14.29	65	75	88.1	101.6	110	132	149.2	179	160	192	217	260.4
5/8"	15.88	95	105	128.7	142.3	150	180	203.4	244.1	220	264	298.3	358
3/4"	19.05	150	185	203.3	250.7	270	324	366.1	439.3	380	456	515.3	618.3
7/8"	22.23	160	200	216.8	271	400	480	542.4	650.9	600	720	813.6	976.3
1"	25.4	250	300	338.8	406.5	580	696	786.5	943.8	900	1080	1220.4	1464.5

METRIC BOLT TORQUE SPECIFICATIONS							
		COARSE THREAD			FINE THREAD		
Size Screw	Grade No.	Pitch (mm)	Foot Pounds	Newton-Meters	Pitch (mm)	Foot Pounds	Newton-Meters
M6	4T	1.00	3.6 - 5.8	4.9 - 7.9	-	-	-
	7T		5.8 - 9.4	7.9 - 12.7		-	-
	8T		7.2 - 10	9.8 - 13.6		-	-
M8	4T	1.25	7.2 - 14	9.8 - 19	1.00	12 - 17	16.3 - 23
	7T		17 - 22	23 - 29.8		19 - 27	25.7 - 36.6
	8T		20 - 26	27.1 - 35.2		22 - 31	29.8 - 42
M10	4T	1.50	20 - 25	27.1 - 33.9	1.25	20 - 29	27.1 - 39.3
	7T		34 - 40	46.1 - 54.2		35 - 47	47.4 - 63.7
	8T		38 - 46	51.5 - 62.3		40 - 52	54.2 - 70.5
M12	4T	1.75	28 - 34	37.9 - 46.1	1.25	31 - 41	42 - 55.6
	7T		51 - 59	69.1 - 79.9		56 - 68	75.9 - 92.1
	8T		57 - 66	77.2 - 89.4		62 - 75	84 - 101.6
M14	4T	2.00	49 - 56	66.4 - 75.9	1.50	52 - 64	70.5 - 86.7
	7T		81 - 93	109.8 - 126		90 - 106	122 - 143.6
	8T		96 - 109	130.1 - 147.7		107 - 124	145 - 168
M16	4T	2.00	67 - 77	90.8 - 104.3	1.50	69 - 83	93.5 - 112.5
	7T		116 - 130	157.2 - 176.2		120 - 138	162.6 - 187
	8T		129 - 145	174.8 - 196.5		140 - 158	189.7 - 214.1
M18	4T	2.00	88 - 100	119.2 - 136	1.50	100 - 117	136 - 158.5
	7T		150 - 168	203.3 - 227.6		177 - 199	239.8 - 269.6
	8T		175 - 194	237.1 - 262.9		202 - 231	273.7 - 313
M20	4T	2.50	108 - 130	146.3 - 176.2	1.50	132 - 150	178.9 - 203.3
	7T		186 - 205	252 - 277.8		206 - 242	279.1 - 327.9
	8T		213 - 249	288.6 - 337.4		246 - 289	333.3 - 391.6

NOTES



***WHEN PERFORMANCE
& DEPENDABILITY
ARE NON NEGOTIABLE !***

**Bercomac Limitée
92, Fortin North, Adstock, Quebec, Canada, G0N 1S0**

WWW.BERCOMAC.COM

PRINTED IN CANADA

(ORIGINAL NOTICE)