



OWNER'S MANUAL

Model number

#701185BER Light duty snow push 62"

#701186BER Light duty snow push 72"

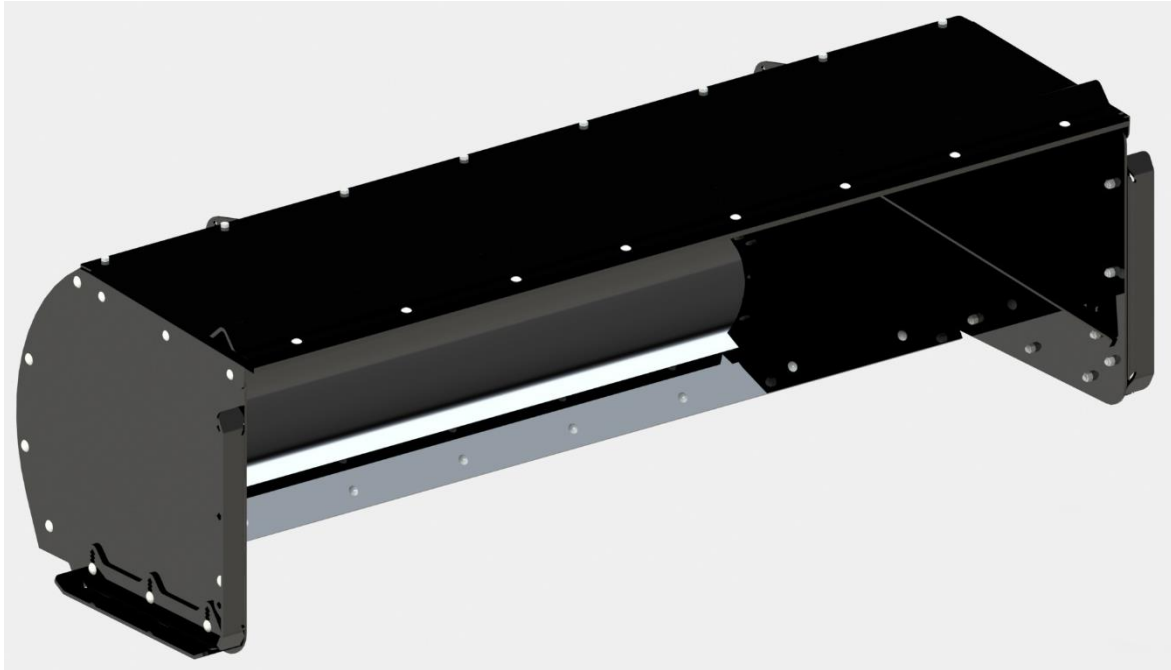

BERCOMAC ***Light duty snow push***

*ASSEMBLY

*REPAIR PARTS

*OPERATION

*MAINTENANCE

CAUTION:

**READ & FOLLOW ALL SAFETY RULES & INSTRUCTIONS BEFORE
OPERATING YOUR EQUIPMENT**



Table of content

Table of content

Introduction	1	Hooking-Up the accessory	12
Important safety information	2	Unhooking the accessory	12
Safety alert symbol/Signal words/Safety messages	2	Operation of the snow push on loader	12
Safety decals.....	5	Operation of snow push back drag	12
Assembly & initial set-up	6	Adjustments.....	13
Vehicle requirements	6	Skid Shoe adjustment.....	13
Reception	6	Maintenance & Lubrication	14
Assembly general instructions	6	Maintenance schedules.....	14
Accessory assembly.....	7	Maintenance procedures	14
Installation of the side blades	7	Skid shoes.....	14
Installation of the brace arms	7	Steel cutting edge	14
Installation of the skid shoes	7	Storage and transportation	15
Installation of the Back drag	8	Long-Term Storage	15
Installation of the skid shoes	8	Transportation.....	15
Initial set-up.....	8	Specifications	16
Accessory Hook-up & Unhook	9	Part list and parts breakdown.....	17
Operating instructions	11	Table de spécification couple de serrage	22
Safety precaution	11	Garantie	23
Controls and display	11		
Operating instructions.....	12		
Pre-start instructions	12		
Vehicle shutdown procedures	12		

Introduction

Introduction

To the purchaser

This new accessory was carefully designed to give years of dependable service. This manual has been provided to assist in the safe operation and servicing of your attachment.

All photographs, illustrations and information in the manual may not necessarily depict the actual models or attachments, but are intended for reference only and are based on the latest product information available at the time of publication.

Familiarize yourself fully with the safety recommendations, assembly, operating procedures, adjustments, troubleshooting, and maintenance before putting the machine to use. It's a necessity for all operators to carefully read, understand and follow these recommendations and insist that they be followed by those who will use this attachment. This manual should be kept for future reference.

Please check if you have received all the parts for your kit with the list of the bag and the list of the box.

Serial number

If applicable, record the serial number and purchase date of your attachment in the section reserved below. Your dealer will require this information to give you prompt, efficient service when ordering replacement parts. Use only genuine parts when replacements are required.

If applicable, the location of the serial number on the accessory is shown in the parts breakdown & part list section of this manual.

SERIAL NUMBER _____ **MODEL NUMBER** _____

PURCHASE DATE _____

If warranty repairs are required please present this registration booklet and original sales invoice to your selling dealer for warranty service.

Terminology

- "Accessory" is used as a general word to describe the product covered in this manual.
- The "right" and "left" side is determined by sitting in the driver's seat facing forward.
- "Vehicle" is a general term to describe the vehicle (tractor, atv, utv, garden tractor,...) the accessory is installed

Further Assistance

If you need any assistance in understanding the information given in the manual and other concerns regarding operation of the machine or for repair parts, safety decals,...

1. Ask your dealership's service representative.
2. If you are not satisfied, seek for general manager of dealership or service manager.
3. If you are still not satisfied, contact us at the address specified on the back page of this manual.

Application

The snow push is designed to push snow straight ahead to clear driveway or parking lot from snow in winter time.

Important safety information

Safety alert symbol/Signal words/Safety messages

These are common practices that may or may not be applicable to the product described in this manual.

SAFETY ALERT SYMBOL



THIS SAFETY ALERT SYMBOL IDENTIFIES AN IMPORTANT SAFETY MESSAGE IN THIS MANUAL THAT HELPS YOU AND OTHERS AVOID PERSONAL INJURY OR EVEN DEATH. DANGER, WARNING, AND CAUTION ARE SIGNAL WORDS USED TO IDENTIFY THE LEVEL OF HAZARD. HOWEVER, REGARDLESS OF THE HAZARD, BE EXTREMELY CAREFUL.

⚠ DANGER: Signals an extreme hazard that will cause serious injury or death if recommended precautions are not followed.

⚠ WARNING: Signals a hazard that may cause serious injury or death if the recommended precautions are not followed.

⚠ CAUTION: Signals a hazard that may cause minor or moderate injury if the recommended precautions are not followed.

PREPARATION FOR USE

All operators, no matter how experienced they may be, should read and understand this and other manuals related to the vehicle and accessory before operating. It is the owner's legal obligation to instruct all operators in safe operation of the accessory to prevent injury or death. Improper use of the accessory can cause serious injury or death.

- Read and understand this owner's manual carefully. Be thoroughly familiar with the controls and proper use of the vehicle and accessory. Know how to stop the unit and handle the controls quickly in case of emergency.
- Read and understand the "Safety Decals" section, read all instructions noted on them or/and in the "Safety Decals" section.
- Never allow children to operate the vehicle nor the accessory. Never allow adults to operate or maintain the vehicle nor the accessory without proper instructions. Local regulations restrict the age of the operator.
- Children are often attracted to accessories. Never assume children will stay in place where you have last seen them. Keep children under surveillance of a responsible adult at all times.
- No one should operate the vehicle nor the accessory while intoxicated or while taking medication that impairs the senses or reactions. The operator should, if taking medication, seek

medical advice on whether he/she can safely operate the equipment.

- Keep the area of operation clear of all people, particularly small children.
- Never start or operate the accessories except from the operator's seat.
- Prepare for emergencies. Be prepared if a fire starts. Keep first aid kit and fire extinguisher handy. Keep emergency phone numbers (doctor, ambulance, etc) near a phone.
- Thoroughly inspect the area where the accessory is to be used and remove door mats, wires, and other foreign objects .
- For motorized accessories, disengage all clutches and shift into neutral before starting engine.
- Do not operate or maintain the accessory without wearing adequate clothing and safety equipment. (glasses, muffs, earplugs, mask...) Wear footwear that will improve footing on slippery surfaces. Prolonged exposure to loud noise can cause hearing impairment or hearing loss.
- Clothing should be snug without fringes and pull strings to avoid entanglement with moving parts.
- Avoid wearing radio headphones while operating.

Important safety information

- Handle fuel with care, it is highly flammable and vapors are explosive.
 - a) Extinguish all cigarettes, cigars, pipes and other sources of ignition.
 - b) Use approved fuel container.
 - c) Never add fuel to a running engine or hot engine.
 - d) Fill fuel tank outdoors with extreme care. Never fill fuel tank indoors.
 - e) Never fill containers inside a vehicle, on a truck or a trailer bed with a plastic liner. Always place containers on the ground, away from your vehicle, before filling.
 - f) When possible, remove gas-powered equipment from the truck or trailer and refuel it on the ground. If this is not possible, then refuel such equipment on a trailer with a portable container, rather than directly from a gasoline dispenser nozzle.
 - g) Keep the nozzle in contact with the rim of the fuel tank or container opening at all times, until refueling is complete. Do not use a nozzle lock-open device.
 - h) Never overfill fuel tank. Replace fuel cap securely and wipe up spilled fuel.
 - i) If fuel is spilled on clothing, change clothing immediately.
- Never attempt to make any adjustments while the engine (motor) is running (except when specifically recommended by manufacturer).
- Let the vehicle and accessory adjust to outdoor temperatures before using.
- Always make sure to have safe traction on the vehicle by using the recommended accessories (chains, tracks, counterweights...). See operation section.
- Always make sure all components are correctly installed. (driveline securely attached and locked at both ends, belts properly installed...)
- Never modify the accessory or any part without the written consent from the manufacturer. Use only options/accessories approved by the manufacturer
- Avoid underground utilities. If the accessory digs into the ground, always contact your local utility companies (electrical, water, gas,...) before digging to know where you can dig.
- Exercise extreme caution when operating on or crossing gravel drives, walks or roads. Stay alert for hidden hazards such as traffic, fences, trees, buildings, wires, etc.
- After striking a foreign object, stop the engine (motor), disconnect the wire from the spark plug(s) and keep wire away to prevent accidental starting. Thoroughly inspect the accessory for any damage and repair damage before restarting and using the accessory.
- If the unit should start to vibrate abnormally, stop the engine (motor) and check immediately for the cause. Vibration is generally a warning of trouble. Do not use equipment until properly repaired.
- Take all possible precautions when leaving the operator's seat. Disengage the power take-off, lower the accessory, place the transmission into neutral, set the parking brake, stop the engine and remove the ignition key to prevent unauthorized starting then wait for all components to come to a complete stop before leaving operator's seat.
- Do not run the engine indoors, except when starting the engine and for transporting in or out of the building. Do not operate or let motor run in a storage area without ventilation because gas contains carbon monoxide which is odorless, colorless and can cause death.
- Never use the accessories across the face of slopes. Go from top to bottom. Exercise extreme caution when using equipment on slopes, on wet ground or near a drop-off. Do not attempt to use accessory on a steep slope.
- Never tolerate bystanders in the working zone or between the vehicle and accessory while hooking-up the accessory.
- Never operate the accessory at high transport speeds. Move and turn vehicle at low speeds during operation. Be cautious when backing up.
- Do not carry or lift passengers on vehicle or accessory.
- Disengage power to the accessory when it is transported or not in use.
- Never operate the accessory without good visibility or light.
- Keep the accessory away from heat sources or flames.
- Never use accessory if it has been dropped or damaged. Repair if necessary before re-using.
- Never use an accessory without proper guards, plates, or other safety protective devices in place

OPERATION:

- Do not put hands or feet near, under or inside rotating parts or any power driven parts

Important safety information

TRANSPORT

- Review Transport Safety instructions in the vehicle manual before moving or hauling.
- Check with local authorities regarding transport on public roads and off road. Comply to all applicable laws and regulations.
- Make sure all lights and reflectors that are required by the local highway and transport authorities (example : SMV (Slow Moving Vehicle), flashing warning light) are in place, are clean, and can be seen clearly by all overtaking and oncoming traffic. Turn on flashing warning light whenever on a highway, except where such is prohibited by law.
- Never have the equipment in operation during transport.
- Always travel at a safe and slow speed to allow adequate steering control and stopping
- Always drive with accessory low to the ground but high enough to avoid any contact with road or any foreign objects during transportation
- Avoid any contact with any overhead power line.
- Never drive the accessories across the face of slopes. Go from top to bottom or bottom to up
- Engage parking brake when stopped on an incline
- Allow for the accessory length when making turns.

MAINTENANCE AND ADJUSTMENT

- When cleaning, repairing or inspecting the vehicle and accessory: park on a solid level ground (in a clean dry area), disengage drives, lower implement, set parking brake, stop the engine, remove ignition key, and wait that all moving parts have stopped and cooled. For gasoline engine, disconnect wire from the spark plug(s) and keep wire away to prevent accidental starting.
- Allow the accessory to cool before working on it
- Use a jack and support blocks to support equipment when required. Carefully release pressure from equipment with stored energy.
- Check all the bolts and components at frequent intervals to make sure that they are properly tightened and in safe working condition.
- When inflating tires, stand on one side NOT in front or over the tire assembly. Use a safety cage if available.
- Remove grease, oil, or debris build-ups.

Remove all tools and unused parts from equipment before operation.

- Disconnect battery ground cable (-) before servicing or adjusting electrical systems or before welding on implement
- Replace parts on this accessory with genuine part only.
- Understands maintenance and adjustment procedure, see adjustment and maintenance section of the owner's manual.
- Never work or walk under the accessory unless securely blocked. Otherwise accessory can fall.
- Visually check for hydraulic leaks and broken, missing, or malfunctioning parts and make necessary repairs before applying pressure to the system. Do the same validation after applying pressure to the system (use a piece of cardboard not your hands to detect leaks).
- Escaping hydraulic oil under pressure can have sufficient force to penetrate skin, causing serious personal injury. If injured by escaping fluid, obtain medical treatment immediately.
- Wear protective gloves and safety glasses or goggles when working with hydraulic system.
- Before disconnecting hydraulic line or performing work, relieve all hydraulic pressure

STORAGE

- Never store a motorized accessory with fuel in the fuel tank inside a building where ignition sources are present such as hot water and space heaters, clothes dryers, and the like. Allow the engine to cool before storing in any enclosure.
- Always refer to the owner's manual when you store the accessory and vehicle for a prolonged or an unspecified length of time.
- Maintain or replace safety and instruction labels, as necessary.
- For winter accessories, (if applicable), let the engine run for a few minutes after clearing snow in order to prevent the rotary parts from freezing.
- Always refer to operator's manual for important details if the accessory is to be stored for an extended period
- Store the accessory in an area where children normally do not play. Secure the implement using blocks and supports and secure any pointy or sharp edges.

Important safety information

Safety decals

Read and understand all instructions/explanations noted on decals or/and in the “Safety Decals” section

- Keep the safety decals clean and visible
- For decal location see part list section of this manual
- Replace decals if decals are missing or illegible
- To buy new decals, see the “further assistance” section in the introduction section of this manual
- To Install new labels
 - Deeply clean area where the label will be installed (remove any grease, rust, dust,....)
 - On textured paint, apply adhesion promoter PRO-FORM PF946C (follow instruction on product label)
 - Peel the decal and install at the proper location (see part list) by pressing on the decal
 - Remove any bubbles under the decal

Decal # 107972



Assembly & initial set-up

Vehicle requirements

The Snow Push is designed to attach to tractor loader equipped with a universal quick attach hitch: Tractor Loader Universal Quick Attach (skid steer quick attach type):

- Horsepower range: 20-40hp
- Maximum vehicle weight: 3500lbs
- Loader minimum lift capacity at full height at pivot pin (C) is 350lbs without back drag and 500lbs with back drag. If length L is less than 1016mm (40"), contact us for calculation.

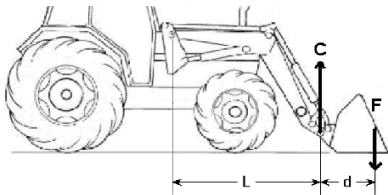

WARNING

To avoid serious injury or death:

Counterweight may be required. Refer to your loader and tractor manual to determine if counterweight is needed. If loader and tractor manual do not have enough information, contact your tractor/loader manufacturer to determine if you need counterweight

WARNING

To avoid serious injury or death caused by vehicle overturn from falling of the vehicle:

Operate only with tractor equipped with an approved rollover-protective structure (ROPS) or ROPS cab and seat belt. Foldable ROPS must be kept up at all times. Fasten seatbelt snugly and securely.

Reception

CAUTION

To avoid serious injury :

Keep Clear. The accessory can flip forward or backward suddenly causing serious injury while removing the accessory from packaging.

1. Remove the fabrane from the shipping crate, remove the sides of the box and the other items attached to the accessory.
2. Approach the tractor with the front loader and hook the accessory to the loader (see hook-up & unhook of the accessory section).
3. Straighten the accessory vertically and position it on a block of wood so that it is approximately 1 inches from the ground.

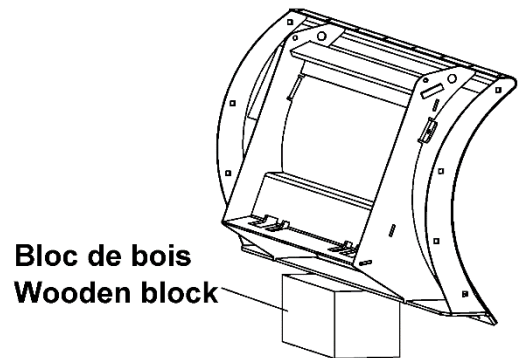

We suggest to do any other assembly after the accessory has been hooked up to the vehicle and securely supported with solid support.

Assembly general instructions

- Unless otherwise specified, torque all bolts to "torque specification table" (see table of content for page number)
- Refer to parts breakdown section for part identification.

Assembly and initial set-up

Accessory assembly



WARNING

THIS ACCESSORY AND ALL OPTIONS ARE HEAVY!

To avoid risk of strain injury, NEVER lift the accessory or any options by hand alone when handling the components or assembly. Use proper lifting device and seek assistance.

When accessory is off the ground, NEVER be underneath the accessory. Serious injury including possibility of death could occur if accessory were to drop suddenly.

Always wear protective shoes and appropriate gloves when manipulating or using this equipment.



DANGER

To avoid serious injury or death :

Proceed to the assembly/adjustment on the accessory after it has been properly attached to the vehicle and secured with solid support. Never work around /under equipment supported by hydraulics. Hydraulics can drop equipment instantly if controls are actuated or if hydraulic lines burst even when power to hydraulics is shut off.

Installation of the side blades

Install the side blades (item 1) using 8 3/8 "n.c. X 1" carriage bolts (item 2) and 3/8 "nylon insert lock nuts (item 3).

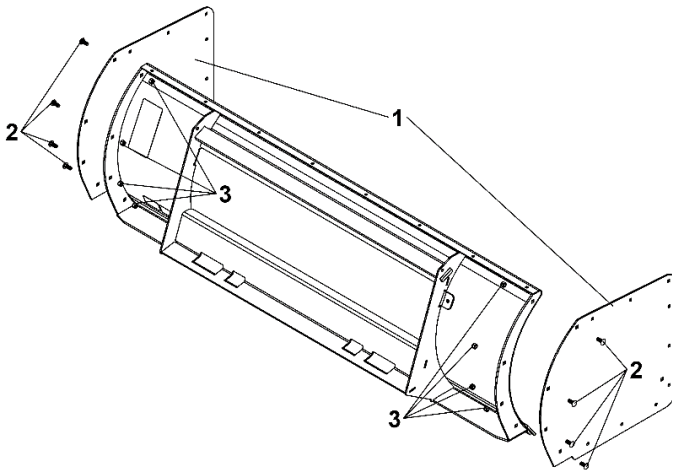

Installation of the brace arms

Install the left (item 1) and right (item 2) brace arms using 2 hex bolts. 3/8 "n.c. X 1" (item 3), 2 3/8 "n.c. X 1" carriage bolts (item 4) and 4 3/8 "nylon lock nut nuts (item5).

NOTE: Pay particular attention to positioning the brace arms in the correct direction.

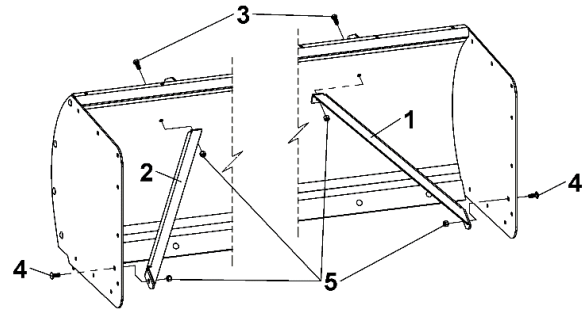

Installation of the skid shoes

Install the skid shoes (item 1) using 6 3/8 "n.c. X 1" carriage bolts (item 2) and 3/8 "nylon insert lock nuts (item 3).

NOTE: For skid shoe height adjustments, refer to the "skid shoe adjustment" section.

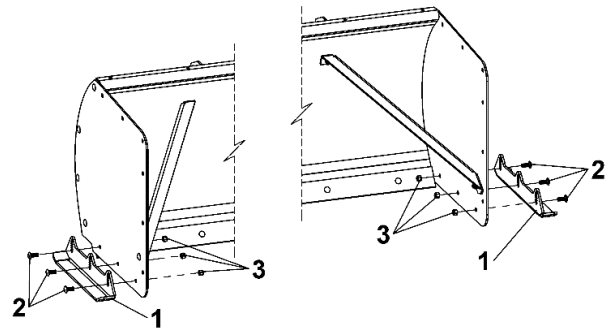

Assembly and initial set-up

Installation of the Back drag

1. Install the back drag (item 1) on the snow push using 8 or 7 (depending on the 72 "or 62" model) hex bolts. 5/16" n.c. X 3/4" (Item 2), 6 5/16" n.c. x 1" carriage bolts (item 3) and 5/16" nylon insert lock nuts (item 4).

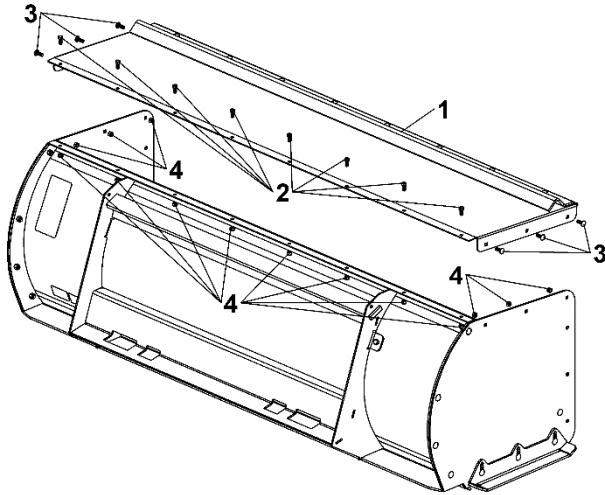

Installation of the skid shoes

Install the skid shoes (item 1) using 6 3/8 "n.c. X 1" carriage bolts (item 2) and 3/8 "nylon insert lock nuts (item 3).

NOTE: For skid shoe height adjustments, refer to the "skid shoe adjustment" section.».

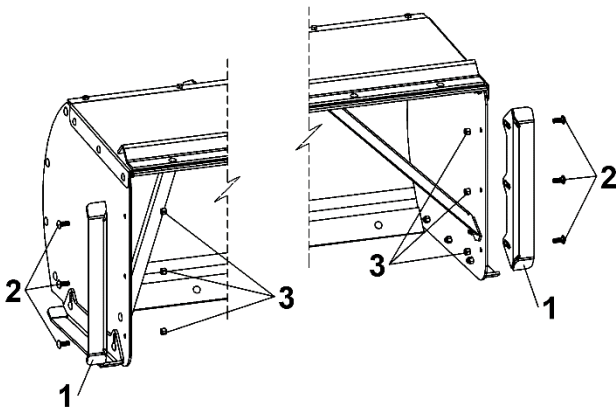

Initial set-up

See adjustment section for complete list of the adjustment

Accessory Hook-up & Unhook

Hooking-Up the accessory - Skid steer quick attach style

DANGER

To avoid serious injury or death :

A Crushing Hazard exists when hooking-up equipment. Do not allow anyone to stand between vehicle and the equipment while hooking-up to implement. Do not operate hydraulic controls while someone is near the vehicle or implement.

WARNING

To avoid serious injury or death :

Make sure the skid steer style loader hitch is properly attached to the quick attach frame. It must be secured under the top angle bar and locking handles must be locked down with locking pins extending fully through the bottom slots. An improperly attached equipment can come loose and fall.

- A. Shutdown vehicle see “vehicle shutdown procedure” in the operation section
- B. Make sure all hooking components are clean and no components will interfere with hitch hook-up. If needed, pull locking handles up on loader hitch until locking pins are fully raised.
- C. Carefully drive up to the accessory making sure loader hitch is parallel with the quick attach frame (item A).
- D. Rotate top of loader hitch slightly forward.
- E. Place top of loader hitch under the top angled bars (item B) on the quick attach frame.
- F. Slowly lift loader hitch up until hitch and top angle bars on the equipment have come together.
- G. Rotate top of loader hitch back to align bottom slots (item C) in the quick attach frame with locking pins on the loader hitch.

- H. Shut down vehicle before dismounting to complete hook-up. Refer to “vehicle shutdown procedure” in the operation section
- I. Push locking handles on loader hitch down until locking pins fully extend through bottom slots (items C) in quick attach frame. Make sure locking handles are locked into position to keep pins from backing out
- J. See hose Hook-up section and electrical Hook-up if applicable

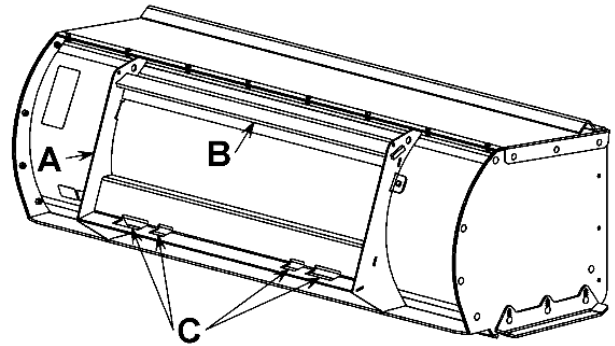

Check interferences

Repeat the following steps for all possible adjustments of the accessory (see adjustment section) and all possible movement of any part of the accessory which affect the position of any part of the accessory relatively to the tractor.

- A. After doing the adjustment, validate that any part of the accessory does not contact any part of the tractor
- B. Slowly move the accessory up and down and validate that any part of the accessory does not come in contact any part of the tractor

Accessory Hook-up & Unhook

Unhooking the accessory - Skid steer quick attach style

Safely lower the accessory



WARNING

To avoid serious injury or death :

Unmounted accessory can be unstable and tip backward once unhooked. Always unhook on a solid flat surface. Always place support blocs under the skid shoe at the back to tip the unit forward. Make sure the accessory tip forward after unhooking. Never unhook with front of accessory facing uphill.

- A. Park vehicle on a solid and flat surface.
- B. Lower the accessory until skid shoes are resting on support blocks at the back of the accessory and on the ground at the front of the accessory.

Place transmission in park, set park brake, shut power equipment off, and remove switch key to avoid accidental starting. See “vehicle shutdown procedures” in the operation section

Remove from Skid Steer Style Hitch:

- A. Remove any electric or hydraulic connections if applicable
- B. Pull lock handles up to remove pins from bottom slots in hitch plate.
- C. Return to vehicle. Start vehicle and tilt top of hitch plate slightly forward toward the equipment.
- D. Slowly lower the equipment until its top angle bar and loader hitch have separated.
- E. Back vehicle slowly away from the equipment while making sure the loader hitch does not interfere with the equipment.
- F. Shutdown the vehicle See “vehicle shutdown procedures” in the operation section.
- G. Check the stability of the accessory to make sure the unit will not tip easily in any direction (forward, backward,...). If required, add support where needed to make sure the accessory will not overturn
- H. Refer to long term storage section if accessory will be stored for a long period

Operating instructions

Safety precaution

DANGER

To avoid serious injury or death :

- Always follow all safety precaution in the important safety information section of this manual.
- Follow all instructions and safety precautions in your vehicle manual and any other related accessory manual.
- Always follow all safety precaution on all safety decals
- To avoid being pinned between loader lift arm or 3pts hitch and vehicle frame, always operate the accessory while seated in the operator seat with seat belt fastened
- Keep any part of your body inside the operator area
- Before leaving the operator's seat, lower attachment to the ground, set park brake, turn off engine and remove key
- Do not use foot or hand control for handholds or steps.
- Keep foot and hand control clean at all time
- Never bypass or modify a safety device
- Keep away from electrical power lines
- Never allow riders on vehicle or accessory
- Operate vehicle only if equipped with ROPS with seatbelt fasten at all time
- Check hitch fit-up frequently. An improper fit-up can result in the accessory detaching from the vehicle
- It is the operator responsibility to make sure nobody is in the working area before performing any work or any movement with the vehicle and accessory
- If applicable stop loader arms gradually when lowering or lifting

WARNING

To avoid serious injury or death:

Counterweight may be required. Refer to your loader and tractor manual to determine if counterweight is needed. If loader and tractor manual do not have enough information, contact your tractor/loader manufacturer to determine if you need counterweight

WARNING

To avoid serious injury or death caused by vehicle overturn from falling of the vehicle:

Operate only with tractor equipped with an approved rollover-protective structure (ROPS) or ROPS cab and seat belt. Foldable ROPS must be kept up at all times. Fasten seatbelt snugly and securely.

CAUTION

To avoid serious injury:

- Use the accessory for the intended purpose only, use only for pushing snow.
- Avoid hitting solid objects with the accessory. Hitting objects can damage the accessory and vehicle. Also hitting solid objects can throw the operator forwards causing severe injury

Controls and display

The accessory is controlled by the loader control on the vehicle.

Follow the instruction in your vehicle/loader manual for proper control of the accessory.

Operating instructions

Operating instructions

Pre-start instructions

Always inspect equipment before using this equipment.
Refer to section “Maintenance and Lubrication”

Vehicle shutdown procedures

Always shut down vehicle before dismounting

1. If engaged, disengage PTO
2. Park on level surface, engage parking brake, lower attachment to the ground, turn off engine, and remove key to prevent unauthorized starting.
3. Wait for all components to come to a complete stop before leaving the operator seat.
4. Use steps, grip-handles, and skid-resistant surfaces when getting on and off the vehicle

Hooking-Up the accessory

See the Accessory Hook-up and Unhook section of this manual.

Unhooking the accessory

See the Accessory Hook-up and Unhook section of this manual.

Operation of the snow push on loader

The accessory is used to clean snow from parking lot or driveway.

To clean snow:

- A. Using the loader control lever, make sure the skid shoe come parallel to the ground
- B. Lower the accessory at the desired location
- C. Use the vehicle to go forward to push snow at around 5km/h (3MPH)

Operation of snow push back drag

This option facilitates to push back snow from close area like garage door....

To clean snow

- A. Extend the hydraulic cylinder to tilt forward the snow push until the back drag skid shoe come parallel to the ground
- B. Lower the accessory at the desired location
- C. Use the vehicle to go backward to push back snow.

Never push snow with the back drag going forward with the vehicle.

Adjustments



DANGER

To avoid serious injury or death :

Proceed to the assembly/adjustment on the accessory after it has been properly attached to the vehicle and secured with solid support. Never work around /under equipment supported by hydraulics. Hydraulics can drop equipment instantly if controls are actuated or if hydraulic lines burst even when power to hydraulics is shut off.

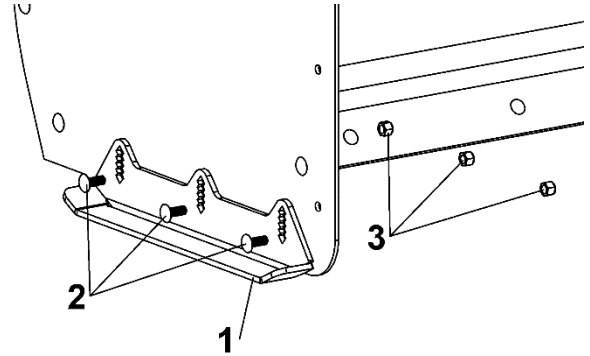

Skid Shoe adjustment

On even surface (paved surface....)

- The skid shoe and the bottom of the cutting edge must be at the same height

On uneven surface (gravel, ...)

- The skid shoe must be lower than the bottom of the rubber cutting edge to create a gap between ground and rubber cutting edge.

To adjust skid shoe, follow the following step:

Before approaching the vehicle, prepare area by placing long and large blocks around 6'' high

- A. Park the vehicle with the accessory mounted on on a flat and level surface.
- B. Lower accessory on the previously placed blocks making sure both skid shoe (item 1) is not in contact with support blocks.
- C. Shut down vehicle before dismounting see "vehicle shutdown procedure" in the operation section.
- D. Remove 3 carriage bolts 3/8'' x 1'' (item 2) and nylon insert lock nut 3/8'' (item 3) on right skid shoe, do the same for the other skid shoe
- E. Place the skid shoe to the desired location and secure in place using the hardware removed at the previous step.
- F. Make sure both skid shoe have the same adjustment.

Maintenance & Lubrication



WARNING

To avoid serious injury or death :

- Always follow all safety precautions in the important safety information section of this manual.
- Follow all instructions and safety precautions in your vehicle manual and any other related accessory manual.
- Use jack and support blocks to support equipment when required. Carefully release pressure from equipment with stored energy.
- Replace parts on this accessory with genuine parts only.
- Never work or walk under the accessory unless securely blocked. Otherwise accessory can fall.
- Never allow untrained personnel to service machine.

Maintenance schedules

Each 8 hours of work.

- Inspect the equipment for skid shoe wear
- Inspect for cutting edge wear
- Make sure all bolts are still at proper location and tight

Maintenance procedures

Skid shoes

The base of skid shoe is 6.35mm (1/4") thick The base of the main skid shoe should be at minimum 3mm (1/8"). If thinner, replace the skid shoe following the same instruction than "skid shoe adjustment" in the adjustment section.

Steel cutting edge

When the steel cutting edge is worn out. The cutting edge can be removed and installed upward to increase lifespan

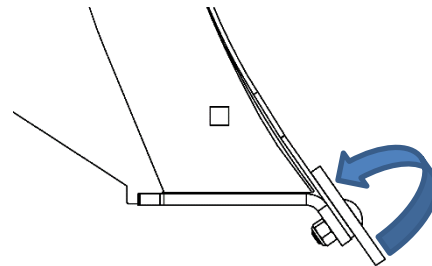

Storage and transportation

Long-Term Storage

Follow unhooking instruction in the section “Hookup and Unhook Accessory” of this manual.

- Clean the accessory
- Inspect the accessory for loose, damaged, missing, or worn parts. Adjust and tighten loose parts. When needed replace parts with new ones.
- Repaint parts where paint is missing or worn
- Replace all damaged or missing decals
- Lubricate all lubrication points see “Maintenance and lubrication” section
- Store accessory on a level surface in a clean, dry place. Inside storage is preferable. Store where kids do not play.
- Check the stability of the accessory to make sure the unit will not tip easily in any direction (forward, backward,...). If required add support where needed to make sure the accessory will not overturn

Transportation



WARNING

To avoid serious injury or death :

When travelling on public roads, use SMV sign, clean reflectors, and any other device to alert others of your presence. Always comply with all federal, state/provincial and local laws

- A. If applicable, always disengage tractor PTO before raising accessory to transport position.
- B. Make sure that any part of the accessory does not contact any vehicle part when raising accessory to transport position.
- C. Travel at safe speed when transporting.
- D. Reduce tractor ground speed when turning and leave enough clearance so accessory does not contact obstacles such as buildings, trees, or fences. Turning at high speeds can result in a roll over of the tractor.
- E. Transport the accessory low to the ground to help maintain vehicle stability and visibility as much as possible
- F. Keep away from electrical power lines
- G. Shift tractor to a lower gear when traveling over rough or hilly terrain.

Specifications

Specifications

Specifications		
Model number	701185	701186
Total width	66 3/8" (1686mm)	76 3/8" (1940mm)
Working width	62" (1575mm)	72" (1829mm)
Height	22 5/8" (575mm)	22 5/8" (575mm)
Depth	28" (711mm)	28" (711mm)
Weight	283 lbs	309 lbs
Capacity (approximative)	15.8 pi ³	18.25 pi ³
Frame thickness	12 Ga.	12 Ga.
Side blade thickness	3/16"	3/16"
Cutting edge	3/8" X 2 1/2"	3/8" X 2 1/2"
Skid	1/4" X 2" X 14"	1/4" X 2" X 14"
HP range	20-40hp	20-40hp
Vehicle weight	3500 lbs	3500 lbs
Lift capacity at full height at pivot pin if installed on loader	350 lbs min if not equipped with back drag	350 lbs min if not equipped with back drag
See NOTE 1	500 lbs min if equipped with back drag	500 lbs min if equipped with back drag

NOTE 1

For lift capacity at full height at pivot pin is installed on loader

If distance L is lower than 1016mm (40") contact us for calculation. The min lift capacity will be higher.

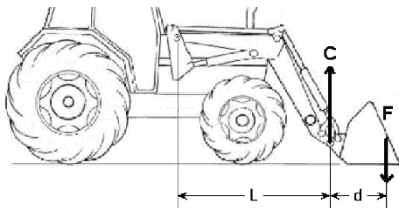

Part list and parts breakdown

Part list and parts breakdown

NOMENCLATURE ET LISTE DES PIÈCES / PARTS BREAKDOWN & PART LIST
Poussoir à neige service léger 62" #701185BER
Light duty snow push 62" #701185BER

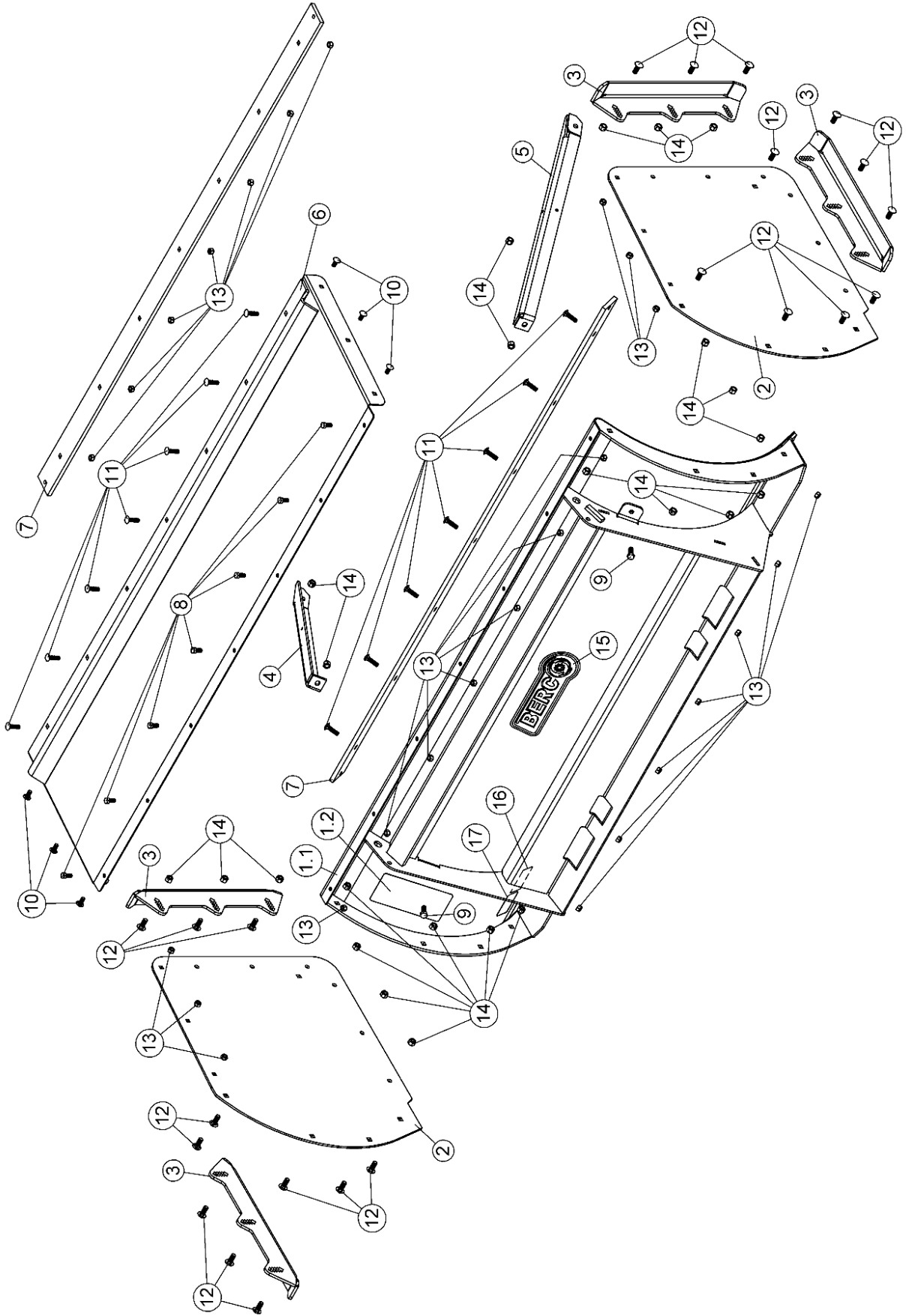

Part list and parts breakdown

NOMENCLATURE ET LISTE DES PIÈCES / PARTS BREAKDOWN & PART LIST Poussoir à neige service léger 62" #701185BER Light duty snow push 62" #701185BER				
REF.	ENGLISH DESCRIPTION	DESCRIPTION FRANÇAISE	QTY.	PART#
1	62" snow push frame #109856 w/ safety decal	Châssis du poussoir à neige 62" #109856 a/ déc. de sécurité	1	109857
1.1	62" Snow push frame	Châssis du poussoir à neige 62"	1	109856
1.2	Vertical warning implement decal	Décalque avertissement accessoire vertical	1	107972
2	Side blade	Lame latérale	2	109849
3	Skid shoe	Patin	4	109850
4	Left brace arm	Bras de renfort gauche	1	109860
5	Right brace arm	Bras de renfort droit	1	109861
6	62" back drag frame	Châssis de panneau de déblaiement 62"	1	109859
7	Cutting edge 62"	Racloir 62"	2	109906
8	Hex. bolt 5/16" n.c. x 3/4" GR5	Boulon hex. 5/16" n.c. x 3/4" GR5	7	O/L (300NC.5P_5-16x3-4)
9	Hex. bolt 3/8" n.c. x 1" GR5	Boulon hex. 3/8" n.c. x 1" GR5	2	O/L (300NC.5P_3-8x1)
10	Carriage bolt 5/16" n.c. x 3/4" GR5	Boulon à carrosserie 5/16" n.c. x 3/4" GR5	6	O/L (320NC.5P_5-16x3-4)
11	Carriage bolt 5/16" n.c. x 1 1/4" GR5	Boulon à carrosserie 5/16" n.c. x 1 1/4" GR5	14	O/L (320NC.5P_5-16x1-1-4)
12	Carriage bolt 3/8" n.c. x 1" GR5	Boulon à carrosserie 3/8" n.c. x 1" GR5	22	O/L (320NC.5P_3-8x1)
13	Nylon Insert lock Nut 5/16" n.c. GR5	Écrou à garniture de nylon 5/16" n.c. GR5	27	O/L (335NC.P_5-16)
14	Nylon Insert Lock Nut 3/8" n.c.	Écrou à garniture de nylon 3/8" n.c.	24	O/L (335NC.P_3-8)
15	Berco decal	Décalque Berco	1	103785
16	Serial number	Numéro de série	1	REF.
17	Made in Canada decal	Décalque Fabriqué au Canada	1	REF.

O/L = Obtain Locally / Obtenir localement

Part numbers starting with 500XXX are not available for sale, however, separate parts are available for sale individually.

Les numéros 500xxx ne sont pas disponibles pour la vente. Au besoin, veuillez commander les numéros de pièces séparément.

Part list and parts breakdown

NOMENCLATURE ET LISTE DES PIÈCES / PARTS BREAKDOWN & PART LIST
Poussoir à neige service léger 72" #701186BER
Light duty snow push 72" #701186BER

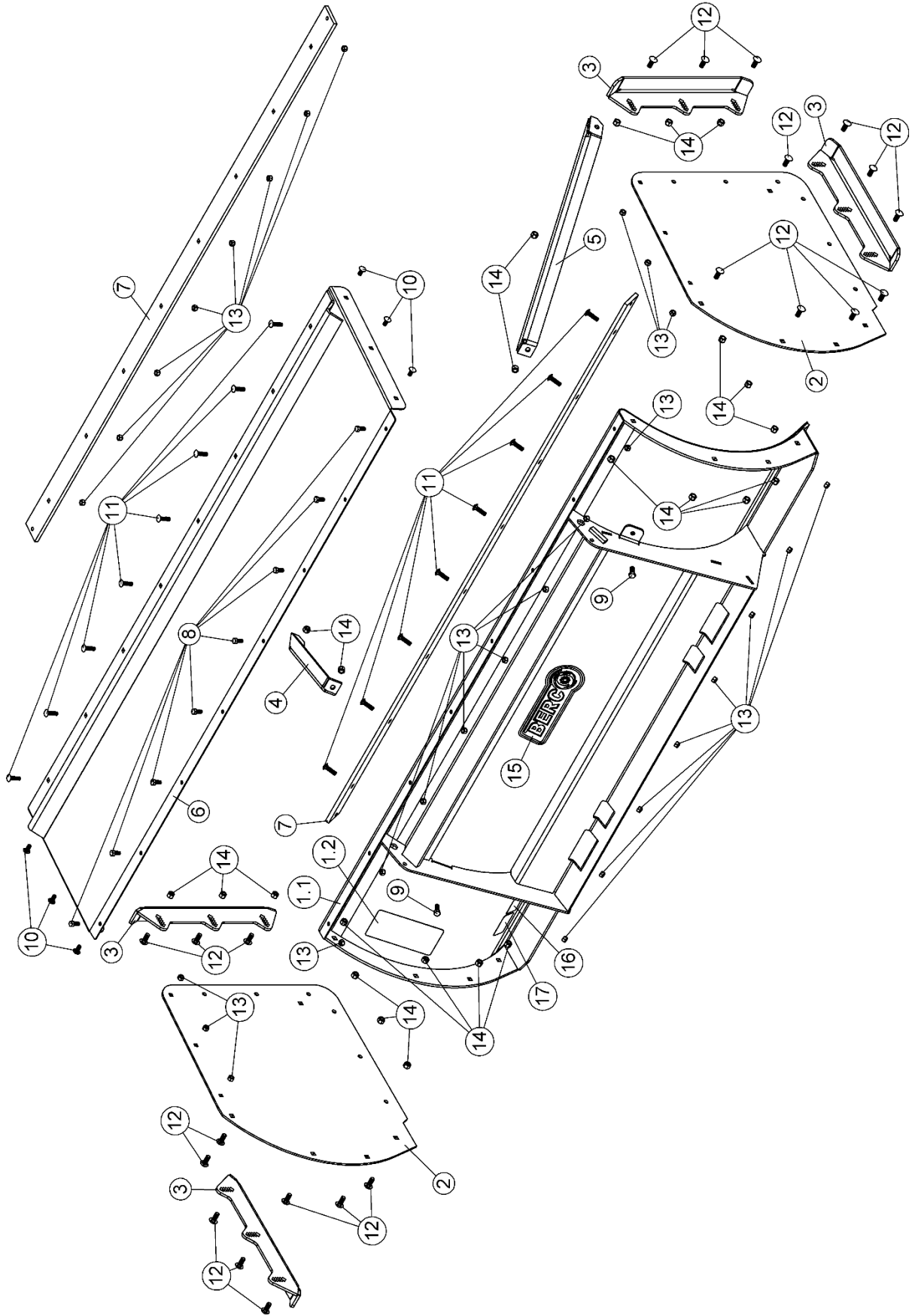

Part list and parts breakdown

NOMENCLATURE ET LISTE DES PIÈCES / PARTS BREAKDOWN & PART LIST Poussoir à neige service léger 72" #701186BER Light duty snow push 72" #701186BER				
REF.	ENGLISH DESCRIPTION	DESCRIPTION FRANÇAISE	QTY.	PART#
1	72" snow push frame #109848 w/ safety decal	Châssis du poussoir à neige 72" #109848 a/ déc. de sécurité	1	109853
1.1	72" Snow push frame	Châssis du poussoir à neige 72"	1	109848
1.2	Vertical warning implement decal	Décalque avertissement accessoire vertical	1	107972
2	Side blade	Lame latérale	2	109849
3	Skid shoe	Patin	4	109850
4	Left brace arm	Bras de renfort gauche	1	109851
5	Right brace arm	Bras de renfort droit	1	109852
6	72" back drag frame	Châssis de panneau de déblaiement 72"	1	109855
7	Cutting edge 72"	Racloir 72"	2	109907
8	Hex. bolt 5/16" n.c. x 3/4" GR5	Boulon hex. 5/16" n.c. x 3/4" GR5	8	O/L (300NC.5P_5-16x3-4)
9	Hex. bolt 3/8" n.c. x 1" GR5	Boulon hex. 3/8" n.c. x 1" GR5	2	O/L (300NC.5P_3-8x1)
10	Carriage bolt 5/16" n.c. x 3/4 " GR5	Boulon à carrosserie 5/16" n.c. x 3/4 " GR5	6	O/L (320NC.5P_5-16x3-4)
11	Carriage bolt 5/16" n.c. x 1 1/4" GR5	Boulon à carrosserie 5/16" n.c. x 1 1/4" GR5	16	O/L (320NC.5P_5-16x1-1-4)
12	Carriage bolt 3/8" n.c. x 1 " GR5	Boulon à carrosserie 3/8" n.c. x 1 " GR5	22	O/L (320NC.5P_3-8x1)
13	Nylon Insert lock Nut 5/16" n.c. GR5	Écrou à garniture de nylon 5/16" n.c. GR5	30	O/L (335NC.P_5-16)
14	Nylon Insert Lock Nut 3/8" n.c.	Écrou à garniture de nylon 3/8" n.c.	24	O/L (335NC.P_3-8)
15	Berco decal	Décalque Berco	1	103785
16	Serial number	Numéro de série	1	REF.
17	Made in Canada decal	Décalque Fabriqué au Canada	1	REF.

O/L = Obtain Locally / Obtenir localement

Part numbers starting with 500XXX are not available for sale, however, separate parts are available for sale individually.







Les numéros 500xxx ne sont pas disponibles pour la vente. Au besoin, veuillez commander les numéros de pièces séparément.







Table spécification couple de serrage

Table de spécification couple de serrage

À UTILISER LORSQU'UN COUPLE DE SERRAGE N'EST PAS SPÉCIFIÉ DANS LE TEXTE

- The following table shows the minimum torque requirement
- Maximum is 15% more than the minimum (example: min100 Nm -> max is 115Nm)
- If specific thread is not specified in the part list or manual, the bolt thread is coarse
- N m = Newton x meter
- Ft-lb = foot pounds
- If bolt is lubricated, divide the torque value by 1.33

IMPERIAL THREAD														
Nominal Thread Diameter	UNC							UNF						
	Thread / inch	Grade 2		Grade 5		Grade 8		Thread / inch	Grade 2		Grade 5		Grade 8	
									N m	Ft-lb	N m	Ft-lb	N m	Ft-lb
1/4"	20	7.4	5.6	11	8	16	12	28	8.5	6	13	10	18	14
5/16"	18	15	11	24	17	33	25	24	17	13	26	19	37	27
3/8"	16	27	20	42	31	59	44	24	31	22	47	35	67	49
7/16"	14	43	32	67	49	95	70	20	49	36	75	55	105	78
1/2"	13	66	49	105	76	145	105	20	75	55	115	85	165	120
9/16	12	95	70	150	110	210	155	18	105	79	165	120	235	170
5/8	11	130	97	205	150	285	210	18	150	110	230	170	325	240
3/4	10	235	170	360	265	510	375	16	260	190	405	295	570	420
7/8	9	225	165	585	430	820	605	14	250	185	640	475	905	670
1	8	340	250	875	645	1230	910	12	370	275	955	705	1350	995
1-1/8	7	480	355	1080	795	1750	1290	12	540	395	1210	890	1960	1440
1-1/4	7	680	500	1520	1120	2460	1820	12	750	555	1680	1240	2730	2010
1-3/8	6	890	655	1990	1470	3230	2380	12	1010	745	2270	1670	3680	2710

METRIC THREAD														
Nominal Thread Diameter	COARSE THREAD							FINE THREAD						
	Pitch (mm)	Class 5.8		Class 8.8		Class 10.9		Pitch (mm)	Class 5.8		Class 8.8		Class 10.9	
									N m	Ft-lb	N m	Ft-lb	N m	Ft-lb
M5	0.8	4	3	6	5	9	7	-	-	-	-	-	-	
M6	1	7	5	11	8	15	11	-	-	-	-	-	-	
M8	1.25	17	12	26	19	36	27	1	18	13	28	21	39	
M10	1.5	33	24	52	39	72	53	0.75	39	29	61	45	85	
M12	1.75	58	42	89	67	125	93	1.25	58	42	95	70	135	
M14	2	92	68	145	105	200	150	1.5	99	73	155	115	215	
M16	2	145	105	225	165	315	230	1.5	155	115	240	180	335	
M18	2.5	195	145	310	230	405	300	1.5	220	165	350	260	485	
M20	2.5	280	205	440	325	610	450	1.5	310	230	650	480	900	
M24	3	480	355	760	560	1050	780	2	525	390	830	610	1150	
M30	3.5	960	705	1510	1120	2100	1550	2	1060	785	1680	1240	2320	

LIMITED WARRANTY

Conditions and Products Covered:

BERCOMAC guarantees any part of the product or accessory manufactured by BERCOMAC and found in the reasonable judgment of BERCOMAC to be defective in material and or workmanship will be repaired or replaced by an authorized dealer without charge up to our maximum labor rates and pre-established times. For replacement parts only standard ground freight services are covered. This warranty extends to the original retail purchaser only and is not transferable to any subsequent purchasers. This warranty applies to the products bought and used in North America.

Warranty Period

(from date of the original retail purchase)

- Residential use: 2 years
- Semi-commercial, professional or rental use: 90 days

Exceptions Noted Below; the following items are guaranteed by the original manufacturer and have their own warranty, conditions and limited time:

- Tire Chains: 90 days
- Engines: Will vary as per the manufacturer

Please refer to the engine manufacturer's warranty statement included with the unit. BERCOMAC is not authorized to handle warranty adjustments on engines.

Items and Conditions NOT Covered:

This warranty does not cover the following:

- Pick-up or delivery charges or in-home services fees.
- Any damage or deterioration of the unit, parts and or finish of these due to normal use, wear and tear, or exposure.
- Cost of regular use or maintenance service or parts, such as gas, oil, lubricants, tune-up parts, and adjustments.
- Any part or accessory which has been altered, modified, misused, neglected, accidentally damaged or not properly installed, maintained, stored or repaired not in accordance with the instructions in the owner's manual.
- Repair due to normal wear and or any wear items such as shear pins, bolts, belts, etc.
- Expedited freight fee services for replacement parts.
- Shear bolts and shear pins are to be considered as a preventive measure not as an assured protection, any damages resulting from the lack of shear bolts breakage are not covered.
- Damages due to product being installed on a vehicle other than stipulated in owner's manual.

NOTE: All warranty work must be performed by an authorized dealer using original (manufacturer) replacement parts.

NOTE: Bercomac reserves the right to change or improve the design of any part or accessory without assuming any obligation to modify any product previously manufactured.

Instructions for Obtaining Warranty Services:

Contact dealer where equipment was purchased or any other BERCO service dealer to arrange service at their dealership. Requests for warranty claims must be carried out through the same distribution network used to purchase the product. Don't forget to bring your proof of purchase (sales receipt) to the BERCOMAC dealer.

Owner's Responsibilities:

BERCOMAC's defective equipment or part must be returned to an authorized dealer within the warranty period for repairs. In the event that defective merchandise must be returned to manufacturer for repairs, freight fees are prepaid and a written authorization from BERCOMAC must be obtained by dealer prior to the shipment. This warranty extends only to equipment operated under normal conditions. To validate a warranty claim, it is the user's responsibility to maintain and service the unit as specified in the owner's manual or to have the unit serviced at their dealer at their expense.

General Conditions:

The sole liability of BERCOMAC with respect to this warranty shall be strictly and exclusively repair and replacement as mentioned herein. BERCOMAC shall not have any liability for any other costs, loss or damage, including but not limited to, any incidental or consequential loss or damage.

Taking advantage of the warranty does not in any way extend the length or renewal of the warranty.

In particular, without being limited to, BERCOMAC shall have no liability or responsibility for:

- Travel time, overtime, after hours time or other extraordinary repair charges or relating to repairs and or replacements outside of normal business hours.
- Rental of like or similar replacement equipment during the period of any, repair or replacement work.
- Any communicating or travel charges.
- Loss or damage to person or property other than that covered by the terms of this warranty.
- Any claims for lost revenue, lost profit or any similar costs as a result of damage or repair.
- Attorney's fees.

BERCOMAC's responsibility in respect to claims is limited to making the required repairs or replacement without charge up to our maximum labor rates and pre-established times and no claim of breach of warranty shall be cause for cancellation or rescission of the contract of sale of any product or accessory. In no event recovery of any kind be greater than the amount of the purchase price of the product sold.

This warranty gives you specific legal rights. You may also have other rights, which vary from state to state.



***WHEN PERFORMANCE
& DEPENDABILITY
ARE NON NEGOTIABLE!***

**Bercomac Limitée
92, Fortin North, Adstock, Quebec, Canada, G0N 1S0**

WWW.BERCOMAC.COM

PRINTED IN CANADA

(ORIGINAL NOTICE)